

IP620 IP PHONE

User Manual



Tables of Contents

1.	About	4
2.	IP620 Overview:	4
3.	Features.....	4
4.	Technical Parameters	5
5.	Inside the box.....	6
6.	Connecting Your Phone.....	6
7.	Adjustable Stand	8
8.	Phone Buttons and Hardware.....	9
9.	IP620 Display.....	10
10.	Placing a Call	11
11.	Placing a Call (pre-dial).....	12
12.	Ending a Call:.....	12
13.	Using Last Number Redial:	13
14.	Last Number Redial One-Button Speakerphone	13
15.	Using Call Logs:.....	14
16.	Answering a call	15
17.	Answering a call while connected to a call	15
18.	Auto – Answer: Answering a call.....	16
19.	Using Hold and Auto Hold.....	17
20.	Transfer a Call.....	18
21.	Transfer Line-to-Line	19
22.	Using Mute.....	19
23.	Do Not Disturb (DND)	20
24.	Selective DND.....	20
25.	Conference – Three-Way	21
26.	Conference Rooms 901 & 902	22
27.	Parking a Call 700.....	22
28.	Phonebook Individual/Enterprise	23
29.	Speed Dial	26
30.	Transfer to Voice Mail	27
31.	Voice Mail	27
32.	Voice Mail – Access from outside	27
33.	Voice Mail – Access from a phone other than your extension	27
34.	Voice Mail Setup (The First Time You Log In)	28
35.	Voice Mail Menus	28
36.	Voice Mail – Listening to Messages	29
37.	Voice Mailbox – Greetings	31
38.	Voice Mailbox – Folders	31
39.	Pause Key	31
40.	Phone Setup – Custom Ringing.....	32
41.	Phone Setup – Smart Personal Console (SPC)	32
42.	SPC – Starting Smart Personal Console.....	32
43.	SPC - Home.....	34

44.	SPC – My Account	35
45.	SPC – Follow-Me Forward – Numbers and Settings.....	37
46.	SPC – My Account – My Phone Settings:	39
47.	SPC – My Phone Settings – Key Settings	39
48.	SPC – My Phone Settings – Audio Settings	40
49.	SPC – My Phone Settings – SIP / Network Settings.....	41
50.	SPC – My Phone Settings – Display Settings	42
51.	SPC – My Phone Settings – Expansion Modules	43
52.	SPC – My Schedule.....	44
53.	SPC – Call Log	45
54.	SPC – Voice Mail.....	46
55.	SPC – Voice Mail – My Greetings	47
56.	SPC Exit.....	48
57.	Volume Adjustments – Receivers/Speaker	48
58.	Volume Adjustment – Microphones	49
59.	Menu.....	50
60.	Buttons and Codes	52

IPitomy Communications, LLC

While every reasonable precaution has been taken in the preparation of this document, neither the author nor the IPitomy Communications, LLC assumes responsibility for errors or omissions, or for damages resulting from the use of the information contained herein.

The information contained in this document is believed to be accurate. However, no guarantee is provided. Periodic changes occur in operation that will affect the information contained herein. Always use the product and become familiar with its operation subjectively.

Use this information at your own risk.

1. About

The IP620 is an enterprise-grade communications device designed to provide the user access to all of the capabilities possible in Voice Over Internet and Voice Over LAN/WAN technologies. The IP620 is a HD® (High Definition) equipped, 2 – SIP-Line phone; SIP is the most advanced packet-switched data transport available for voice communications. Through the use of SIP-Gateways the IP620 is also capable of interfacing the legacy telephony network.

HD IPitomy's HD telephones use wideband speech CODECs which encode 7.1KHz of the voice spectrum instead of the standard 3.4KHz. This doubles the bandwidth for communications and elevates voice quality substantially. Combine HD audio with IPitomy's acoustically tuned housing, and the end result is industry-leading speakerphone clarity.

Your IP620 can utilize the g.722 codec and provide HD audio while taking up no more bandwidth than the standard g.711 codec. This means better sound and no sacrifice.

2. IP620 Overview:

- 4 dynamic, context-sensitive soft keys
- 2 SIP Line keys for use with up to two SIP extensions (SIP Accounts) or two appearances of the same extension (SIP Account)
- Up/Down/Right/Left and OK Navigation keys
- 12 programmable keys (speed-dial/feature keys)
- Segmented and fixed features access and call processing keys for ease of use
- 12-key standard telephone dial pad
- Big Red speaker button to answer and disconnect calls
- All Clear button for easy navigation back to original menu position
- Multi-position Stand
- Integrated Wall Mount
- Dual 10/100Mbps auto-sensing Ethernet ports with integrated PoE
- High Definition Audio
- Auto provisioning to IPitomy IP PBX
- Enterprise Phone Book
- Personal Phone Book

3. Features

- 128 X 64 Pixel Grey Scale LCD
- 2VoIP accounts
- HD Voice: HD Codec
- BLF
- Business Features – Park, Page, Group Page, Hands Free
- XML Enterprise Phonebook
- XML Personal Phonebook
- Headset Mode with two alternatives for connectivity – RJ9 and 3.5mm Audio
- PoE, 2xRJ45
- Supports up to 6 Expansion Modules
- 12 Programmable keys
- Encryption

4. Technical Parameters

Item	IP620
Screen	Color Graphics Backlit Display
	480x272 pixels
	Various Use icons and Features Status icons
Language	English, Chinese
SIP Lines	8 (Up to eight Session Initiation Protocol accounts possible)
Function Keys	4 Soft keys, 8 Programmable Line keys (dual-color LED) 6 Navigation keys (arrow button, OK button, Clear button) 12-key telephone Dial Pad Volume adjust bar +/-, Speakerphone (Red button), Mute, Headset, Message, Menu, Directories, Service, Hold, Redial, Conference, Transfer
VoIP Protocol	SIP 2.0
Network	2 - RJ45 10/100M Ethernet interfaces (LAN/PC) IP Assignment: Static IP or DHCP DNS Client
Network Protocol	TCP/IP, HTTP, BOOTP, TFTP, *IEEE 802.1Q, *IEEE 802.1X
Codec	G.723.1, G.729 A, G.711 A/U, G.722
QoS	TOS, Jitter Buffer, VAD, CNG, G.168 (32ms)
Call Processing	Line Status Indicator (dual color LED) Eight Accounts possible Call Waiting, Call Queuing, Line Switching Call Forward, Call Transfer, Call Holding, Call Pickup, Call Park, Page Callback One Key Dial, Redial Phone directory speed dial, Call record direct dial 3-way conference (Phone capacity) Do Not Disturb Voice mail, Voice Prompt, Voice Message BLF (Busy Lamp Field)
Expansion Interface	The port "EXT" on the bottom of the phone is used to interface the IPX32 expansion module. This expansion module adds 32 keys per module. Six total modules can be used with the IP410. An external power adapter is required when 4 or more expansion modules are installed.
USB	Future Use
Security	User Authentication for configuration pages Signaling encryption Media encryption
Application	Public phone directory Private phone directory Auto Discovery / Auto Provision
Power Supply	Power adapter: AC 100-240V input and DC 12V/1A output (not included) PoE (IEEE 802.af)
POE WATTS	Power consumption of the IP620 is 5 WATTS... add 2 WATTS for each Expansion Module attached. When using more than 3 Expansion Modules use an external power supply (Model: PS346).
Environment	Storage Temperature: 0° - 60° C Operating Humidity: 10% - 90% Size 254mm*205mm*87mm

5. Inside the box

If you are removing the IP620 from its carton, you can check the contents against the following list to assure that all parts have been received:

Item	Quantity
HD-compliant IP Speakerphone	1
HD-compliant Handset	1
1.5-meter Handset Cord	1
3-meter RJ45 cable	1
Wall Mount Template	1

6. Connecting Your Phone

Your system administrator will likely connect your new IPitomy IP620 IP Phone to the corporate IP telephony network. If not, use the steps and figures to connect your phone and setup your telephone.

- 1) Connect the Handset Cord into RJ9 (4) (Figure 2)] connector on the underside of the telephone.
 - a) Inspect the handset cord and notice that one end has an extended portion that is flat (not coiled). This is the end of the cord is to be placed into the molded plastic channel leading from the connector to the edge of the telephone.
- 2) Connect the LAN connector to the telephone to the Telephony enabled network.
 - a) When your network is PoE (Power Over Ethernet) equipped it will not be necessary to use a power supply with your telephone. If not, you will need the optional power supply (PN: PS346) to use your phone.
- 3) You may also connect a PC to the "PC" connector to facilitate that PC's network connection.

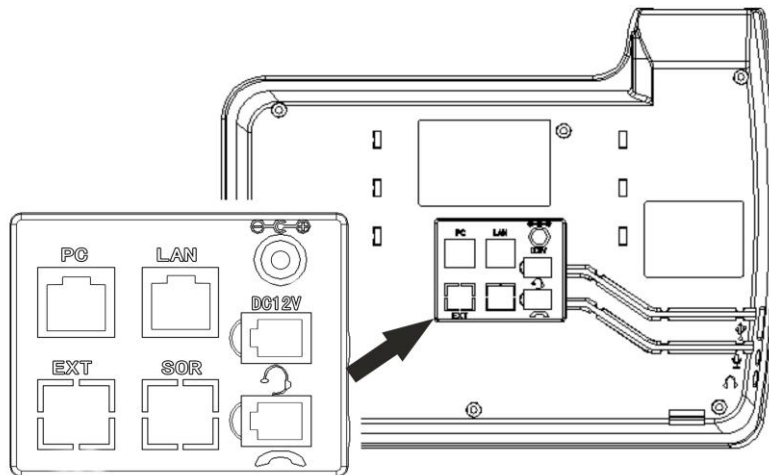

Figure 1 Connections on the back of IPitomy IP620

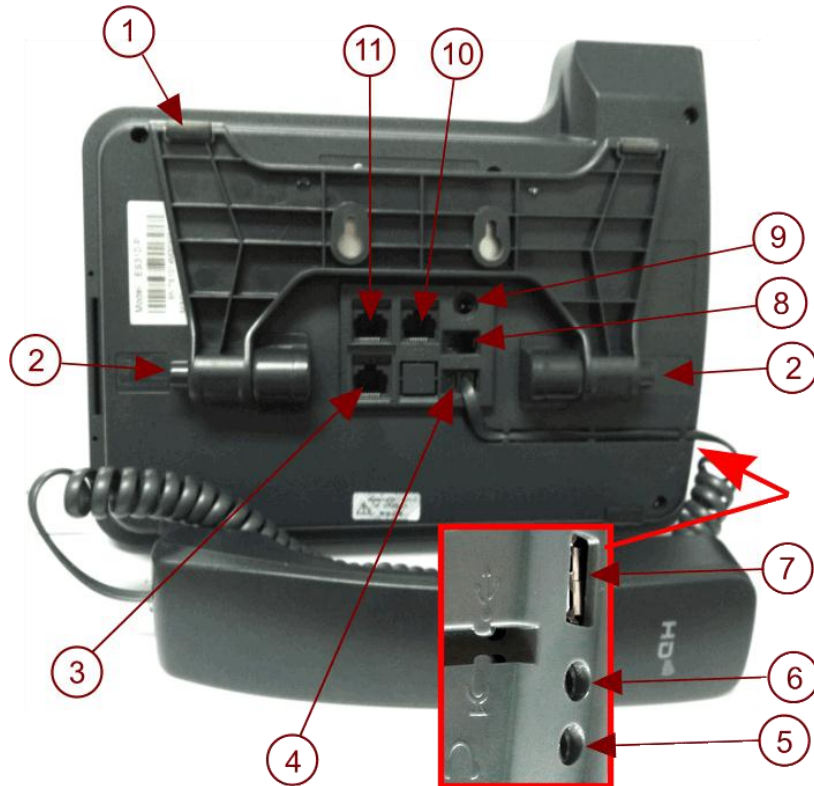

Figure 2 Photo of connections and definitions

	Hardware	Functions
①	Adjustable Stand (integrated Wall Mount)	The telephone viewing angle may be adjusted to suit your preference. Press in button (2) and adjust as you wish. In the position shown (all the way up) the telephone can be wall mounted.
②	Stand Adjustment Button	Press buttons at the same time to adjust the angle
③	Expansion connector	EXT: IXP32 interface; Use to Plug in expansion module SOR: (adjacent to "EXT") Unused
④	Handset connector	Connect the Handset
⑤	Headphone port	Connect the Headphone
⑥	Microphone port	Connect the Microphone
⑦	USB port	Reserved for future functionality
⑧	Headset port	RJ9 – Type Headset connection
⑨	Power connector	Used with optional Power Supply (PN: PS346) 12VDC
⑩	LAN connector	Connect to Telephony-enabled LAN (PoE preferred)
⑪	PC port	Connect to a local PC (if desired)

7. Adjustable Stand

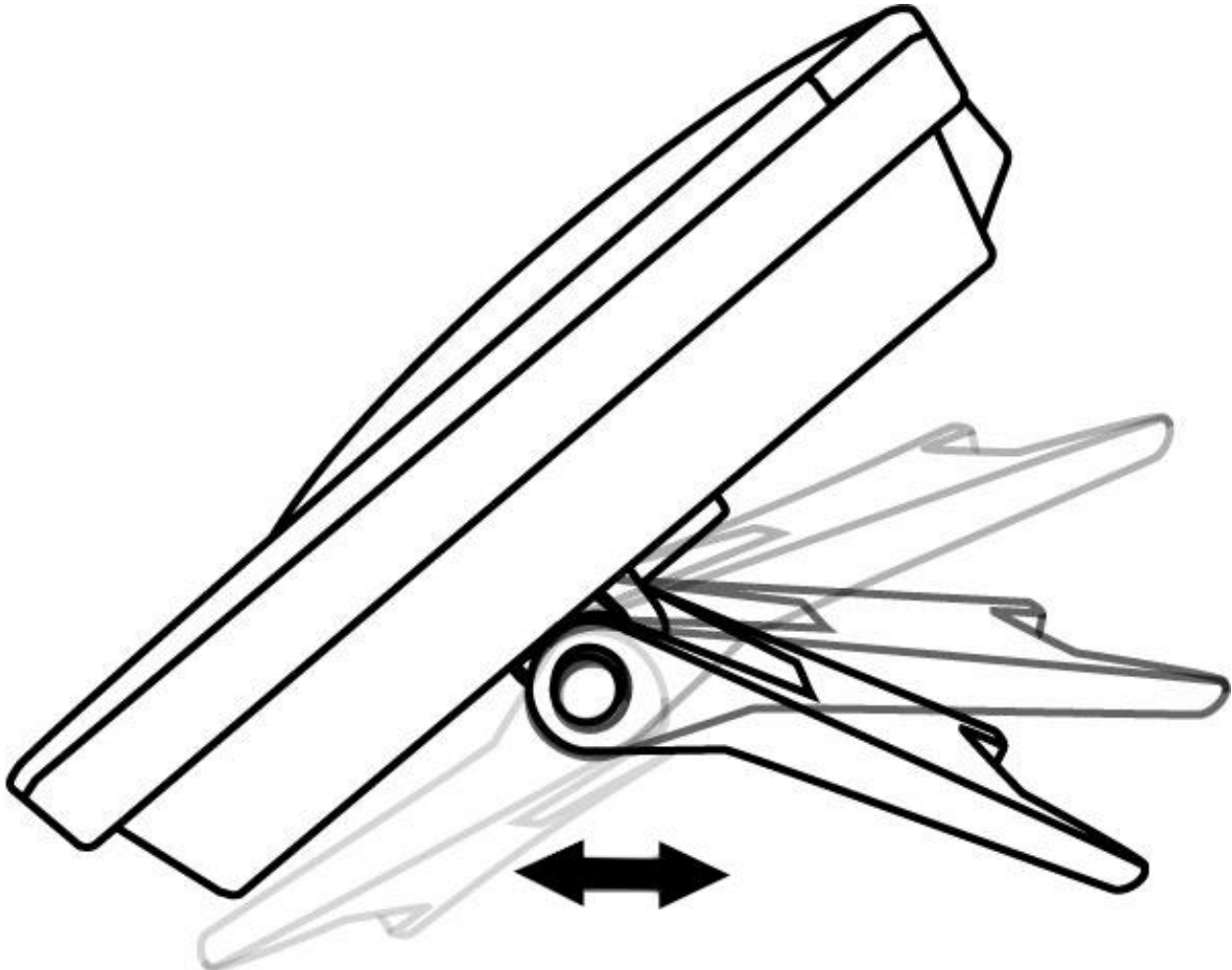

Figure 3 Adjustable Stand

Your IP620 telephone is equipped with an integrated universal adjustable positioning stand. This feature allows you to position the telephone as you wish for your own optimum viewing angle. The design of the stand also allows the telephone to be wall mounted if desired – no additional parts are required.

For wall mounting, use the included wall mount template to position screws (not included) on the wall surface. (Care should be taken to secure the mounting screws adequately with consideration of the wall material.)

8. Phone Buttons and Hardware

1		Headset: Toggles the headset on or off (Red) active
2		Service: Future Use – no uses at this time
3		Mute: Toggles the Mute feature on/off (Red) when MUTE active
4		Directories: Use to access Call History and Phone Books.
5		Messages: Use to access voice mail Red = unheard voice messages waiting
6		Menu: Used to set features and access programming.
		7 480X272 Color LCD Display all various call data
		8 Graphics-compatible photo/logo display
		9 Programmable Buttons: <ul style="list-style-type: none"> frequently used function user status (BLF) display SIP Line Activity Select/Answer Lines Line Status Lamps <ul style="list-style-type: none"> Red, flashing: ringing call Red, steady: call setup Green, flashing: Holding call Green, steady: Active call
		11 Soft Keys: activate displayed function using associated button (key) below
10	Light Bar	Indicates In-Use status
12		Microphone (for hands-free operations)
13		Clear: used similarly to abort displayed menu prompts and return to previous/Home
14		Navigation and Select "OK" buttons for use in menu operations and call processing
15		
16		Speakerphone: answer and place calls using the hands-free speakerphone



Figure 4 IPitomy IP620 Buttons and Hardware Definitions

17		Dial Pad: Basic Call Placement, AND: Press to send a dialed number
18	Speaker	The speaker used in all hands-free operations
19		Hold: Place calls on hold
20		Transfer: Transfer a connected call to someone else
21		Volume rocker: Controls the volume for all various modes Volume settings are retained for each function: <ul style="list-style-type: none"> Handset Headset Hands-free Speakerphone Ringer
22		Conference: Build phone-based conference calls (3-parties max.)
23		Redial: Redials the last number

9. IP620 Display









1	Time and Date	Current time and date is displayed
2		Features Status
		Missed Call(s)
		Auto Answer mode active
		Mute active
		DND (Do Not Disturb) active
		Phone Call Forward active
		Network Link status = disconnected

3	Display Page Tabs	Phone Standby Menu/Call History Phone Book Services
4	Call Status & graphics Uses include:	<ul style="list-style-type: none"> • Caller ID Name and Number • Number dialed • Visual Volume setting • Missed Call listing • Boot-up photo (1) • Standby photo (1) • Idle screen photos (2)
5	Soft Keys	Various feature operations and dynamic to the call in progress.
6	SIP Line SIP Line and status are shown here. The display is programmed to show the extension or line that is accessed by the associated button. In this case, PBX extensions 4950, 4951, and 4952. Green: • Flashing = Hold • Steady = Connected, or Busy Phone Red: • Flashing = Ringing • Steady = Line Busy	Line Registered and Idle
		Line NOT registered
		Line during call setup before connection
		Line In Use connected
		Line on Hold flashing green
		Line in Transfer state
		Line Ringing flashing red
Line In 3-Way Conference		
7	Extension label	Monitored Line status (BLF)
		Line in Do Not Disturb flashing green

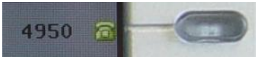
10.Placing a Call

There are three ways to use your phone for calls:

1. Using the handset
2. Using the Speakerphone
 - a. Use of the speakerphone is convenient and desirable for many calls, however the environment in which the phone is located must be taken into consideration when using the speakerphone. Acoustic properties and ambient noise will impact the performance of your speakerphone.
3. Using a Headset
 - a. Using a headset requires that an ancillary headset device be connected to either the RJ9 connector on the back of the phone or to the 3.5mm Microphone and Speaker connectors on the side of the phone.

Steps:	1	2	3
Handset Call	Lift Handset		
Speakerphone Call	Press  Speaker Button, OR:  Idle Line Button OR:  Soft Key	Dial Number 	Press  OR 
Handset Call	 Headset Button		Your call will be connected  Line Lamp Steady Green

Notes:

- 1) The IPitomy PBX will automatically place your call based on the number dialed.
 - a) Extension calls and network numbers are dialed in the same manner.
- 2) When calling an IPitomy telephone extension it is possible to place the call with hands-free reply. To do this

preface the extension number with .

- 3) The example in the display in these instructions shows extension 4950. Your phone line number will likely be different.





11.Placing a Call (pre-dial)

Steps:	1	2	3	
Handset Call			Lift Handset	
Speakerphone Call	Dial Number 	Press: to make corrections in number OR: to abort	Press Speaker Button, OR: Idle Line Button OR: Soft Key	Your call will be connected Line Lamp Steady Green ("4950" is an example of a line number)
Headset Call			 Headset Button	

12.Ending a Call:

Steps:	1
Handset Call	Hang Up Press Speaker Button OR Soft Key
Speakerphone Call	 Speaker Button OR Soft Key
Headset Call	 Headset Button OR Soft Key



13. Using Last Number Redial:

Steps:	1	2
Handset Call	Lift Handset	
Speakerphone Call	Press  Speaker Button, <i>OR</i> :  Idle Line Button <i>OR</i> :  Soft Key	Press  REDIAL
Handset Call	 Headset Button	

Note:

The example in the display in these instructions shows extension 4950. Your phone line number will likely be different.

14. Last Number Redial One-Button Speakerphone

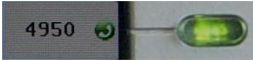
Steps:	1
	Press  REDIAL <i>OR</i>  ReDial
	Your call will be connected  Line Lamp Steady Green

Note:

The example in the display in these instructions shows extension 4950. Your phone line number will likely be different.















15. Using Call Logs:

Your IPitomy IP620 telephone will store 100 numbers each for the following Call Logs:



- Missed Calls
- Received Calls
- Dialed Numbers

These numbers can be stored on your personal Phone Book or dialed directly from the list.

Follow these steps to retrieve a number from those saved on your telephone.







Steps:	1		2	3	4	5	6
Dialed Numbers		Right Nav. Key	Use the Up and Down Navigation Keys to find the number you want.	Press  OR:  to view call data	From View press  To store in your Phone Book		
Missed Calls		Down Nav Key					
Received Calls		Up Nav Key					
Phone Book & Call History		Directories Button	Use the Up and Down Navigation Keys to select "Calls"	Use the Up and Down Navigation Keys to select the Call Log desired	Use the Up and Down Navigation Keys to find the number you want.	 OR  to view call data	From "View" press  To store in your Phone Book
Menu Access to Call Logs	 OR 	Navigation "OK" Key	Use the Up and Down Navigation Keys to select "Calls"	Use the Up and Down Navigation Keys to select the Call Log desired	Use the Up and Down Navigation Keys to find the number you want.	 OR  to view call data	From View press  To store in your Phone Book

Notes:

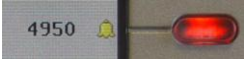
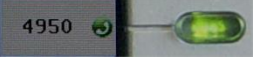
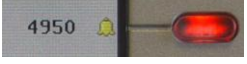
- 1) Use soft-keys  to delete one entry or  to delete all entries in a call log.
- 2) When saving a dialed number to your Phone Book, you may modify the number and name as required/desired. Use  to modify the name and/or number
- 3) An asterisk (*) in front of a Missed Call entry identifies missed calls not previously viewed.

16. Answering a call

You can answer a call by simply lifting the handset. To answer using one of the other call options:





Steps:		1	2	To End Call
Answer Using Handset	Line Ringing  Line Button flashing Red	Lift Handset	You will be connected to the ringing call 	Hang Up
		Press  Line Button, OR:  Soft Key, OR:  Speaker Button		Press  OR: 
Answer Using Speakerphone				
Answer Using Headset		Press  Headset Button		Press 

Notes:

- 1) Your IP620 gives you the option of Rejecting a ringing call. To do so press  while ringing.
- 2) The example in the display in these instructions shows extension 4950. Your phone line number will likely be different.

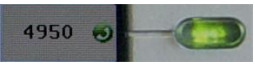
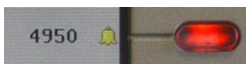



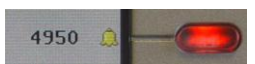



17. Answering a call while connected to a call

Answering a new call while connected on a call is enhanced with Auto Hold (see Using Hold and Auto Hold). The streamlined steps to making this function are:

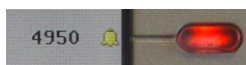



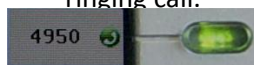



Steps:	1	2	note 1	note 2
Line connected 	Press Ringing (flashing)  Line Button	You will be connected to the ringing call.  Steady Green	The previous call is automatically placed on hold  Flashing Green	You may reject the ringing call and send the caller to Voice Mail. To do so press:  Soft Key
Line Ringing  Line Button flashing Red				

18.Auto – Answer: Answering a call

Auto Answer simplifies answering calls by connecting them automatically. When this mode is active all calls to the extension will be answered automatically in the respective modes.

	Idle Status	Auto Answer	To End Call
Answer Using Handset	Handset off-hook		Press 
Answer Using Speakerphone	 Speaker Button idle	Line Ringing  Line Button flashing Red	Press   OR
Answer Using Headset	 Headset Button	You will be connected to the ringing call.  Steady Green	Press  OR 

Activate Auto Answer

- 1) At Idle phone press 
- 2) Use the Navigation keys and scroll to “Function settings” and press  or .
- 3) Use the Navigation keys and scroll to “Auto answer” and press  or .
- 4) Use the Navigation keys and scroll to “Enable” and press  or .
- 5) Press  to exit the menu. Auto Answer is now active.
- 6) The example in the display in these instructions shows extension 4950. Your phone line number will likely be different.

19. Using Hold and Auto Hold

Hold

You can hold calls and then retrieve them when you're able.

Auto Hold

Your IP620 will automatically hold calls for you. While already on one line – press another (ringing or idle); the first call is held and the next line is accessed.

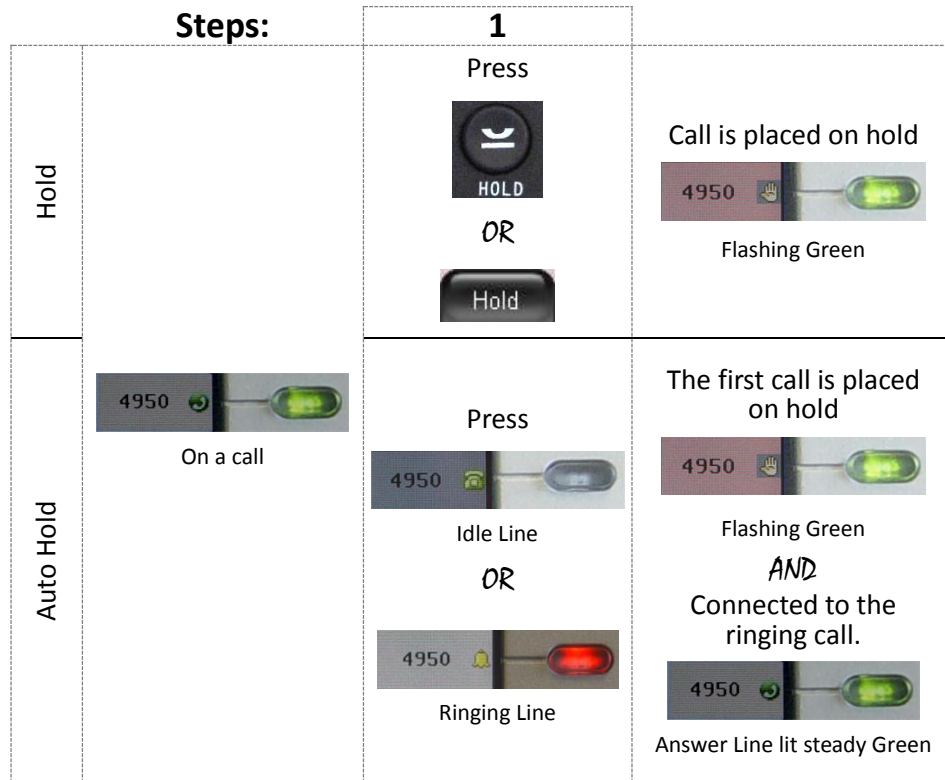

Notes:













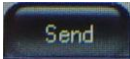

- 1) To retrieve a call from Hold, press the desired holding line button  (flashing green).
- 2) Callers on hold usually hear music or a periodic tone to indicate their status – on-hold.
- 3) The example in the display in these instructions shows extension 4950. Your phone line number will likely be different.

20. Transfer a Call

Call Transfer is used to direct a call from your telephone to the exact destination you wish. In the steps below the “target” is the number to which you want the call to be delivered.

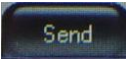
There are two techniques you can use to transfer calls:

- Blind – used to deliver the call to the target expeditiously
- Announced – announce the call transfer to the target before completing the transfer

		Steps:	1	2	3	4
Blind Transfer			Press  OR: 	Press  Blind	Input  Extension No.	Press  OR  The call is moved from your telephone to the target
	 On a call		 OR: 	Input  Extension No.	Press  OR  Wait for the target to answer and then announce the transfer	To complete the transfer press  OR:  To cancel the transfer and retrieve the call, press 

Notes:

- 1) Blind Transfer will convey the Caller ID of the call being transferred.
- 2) Announced Call Transfer will convey the Caller ID of your extension since that was the call connected prior to the transfer taking place.
- 3) You can transfer a caller to an extension’s voice mailbox to leave a message by inserting a  before the extension number (see Transfer to Voice Mail.)
- 4) The example in the display in these instructions shows extension 4950. Your phone line number will likely be different.

21. Transfer Line-to-Line

Sometimes it's desirable to transfer a call to a line that you have previously placed on hold. The IP620 makes this possible with Transfer Line-to-Line.

In this operation, one caller is on hold and the other is on the active line (connected to you). To connect these two people together simply transfer the connected call to the held call. As follows:

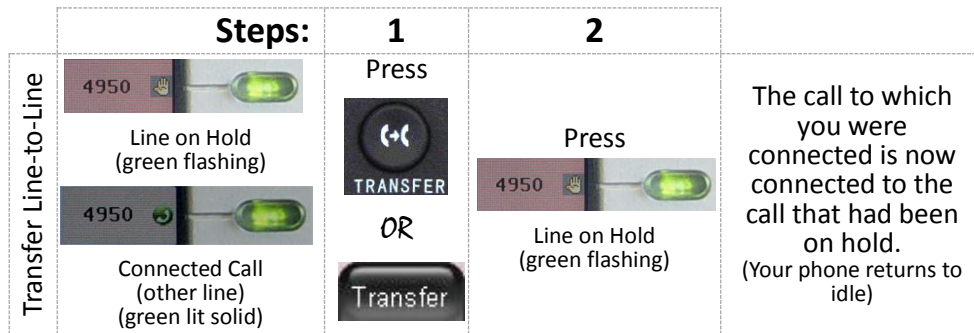

Note:

The example in the display in these instructions shows extension 4950. Your phone line number will likely be different.

22. Using Mute

When Mute is active, you can hear other parties on a call but they cannot hear you. You can use mute in any of the modes:

- Handset
- Speakerphone
- Headset

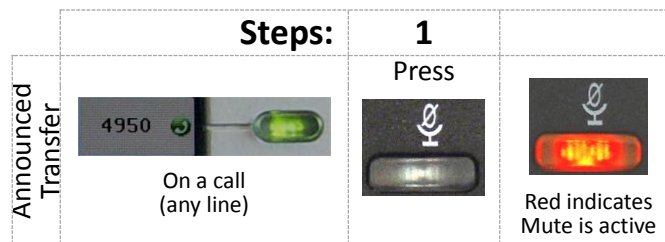



Notes:

- 1) Mute May be activated prior to connection.
 - a) Press Mute then lift handset
 - b) Press Mute then press Speaker Button
 - c) Press Mute then press Headset Button
- 2) Mute may be activated and deactivated during a conversation
- 3) When a connection is ended, Mute will automatically deactivate
- 4) The example in the display in these instructions shows extension 4950. Your phone line number will likely be different.

23. Do Not Disturb (DND)

You can use Do Not Disturb (DND) to block incoming calls to your phone.

Steps:		1
Do Not Disturb	 While Idle	Press 
		 The DND icon appears in the features area of the display and on all lines indicating DND is active.

Notes:

- Callers will hear busy tone when they call the extension in DND
- You can still make calls on a line that is in DND.
- To cancel DND just press  again







24. Selective DND

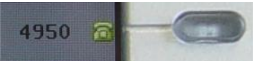

Since up to eight SIP Accounts may be registered on your phone you may wish to activate DND on one or more specific SIP Lines. While leaving others available The IP620 accommodates this nicely with Selective DND.

In the photo notice:

- two of the lines are extension 4950, the first is on hold, the second is idle, and
- one line is extension 4951, and
- One line is extension 4952
- Extensions 4951 and 4952 are in DND

Steps:		1	2	3	4	5	6
Selective DND	 While Idle	Press 	Scroll to "Function Settings" and Press 	Scroll to "DND" and Press 	Scroll to the Account to place in DND. (In the example "5555" is Account02) Then press 	Scroll to "Enable" and press 	Press  to exit the menu and your selected line will be in DND.











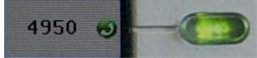









Notes:

- 1) To cancel Selective DND repeat the process and select "Disable".
- 2) To cancel all DND, press  twice.
- 3) The example in the display in these instructions shows extension 4950. Your phone line number will likely be different.

25. Conference – Three-Way

Conference calling allows you to merge two other people onto a connection on your telephone. (3-way conference = you and two others.) When using an IPitomy IP PBX, conference capacities are greatly increased through the use of Conference Rooms. Conference – Three-Way is a telephone centric feature.

Perform the following steps to establish a three-way conference call on your telephone:





	Steps:	1	2	3	4	5	6
Conference from transfer	 On a call (any line)	Press  OR: 	The transfer is initiated 	Input  Extension No.	Press  OR  Wait for the target to answer and then announce the transfer	If you decide to conference rather than transfer just Press 	The conference is established 
Conference from idle	 Idle Line	Place your first call using Placing a Call	Press  OR: 	Place your second call using Placing a Call	Press  OR: 	The conference is established 	
Conference from Hold	 Line on Hold	Place a Call That which will be merge to holding line	Press  OR: 	Press  Holding line	The conference is established 		

Notes:

- 1) Conference – Three-Way is a telephone function and does not impact the Conference Rooms of the IPitomy IP PBX.
- 2) You may exit a Three-way Conference at any time – doing so will leave the other two parties connected in their own private conversation.
- 3) A Three-way Conference call cannot be transferred.
- 4) A Three-way Conference can be placed on hold.
 - a) While on-hold the holding parties are not connected to one another.
- 5) The example in the display in these instructions shows extension 4950. Your phone line number will likely be different.

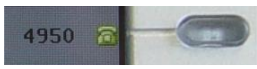
26. Conference Rooms 901 & 902

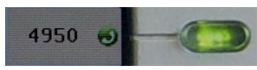
Conference Rooms are an IPitomy IP PBX feature and allow up to 32 parties to be connected. All IPitomy IP PBX's are equipped with two Conference Rooms minimum (Room 901 and Room 902). Additional Conference Rooms are available as an option. Use of Conference Rooms is quite easy and streamlines grouping any number of people up to 32 maximum in any one conference.

Steps:		1	2	
From Idle	 While Idle	Use Placing a Call operation and place a call to any Conference Room	Input  Conference Room No.	You are connected to that Conference Room
Transfer to Conference Room	 On a call (any line)	Use Transferring Call operation and transfer this call to any Conference Room	Input  Conference Room No.	The call being transferred is connected to that Conference Room

Note:

- 1) Callers may enter Conference Rooms from a Menu (Auto-Attendant)
- 2) A Conference Room PIN (password) may be required.
- 3) The example in the display in these instructions shows extension 4950. Your phone line number will likely be different.

27. Parking a Call 700

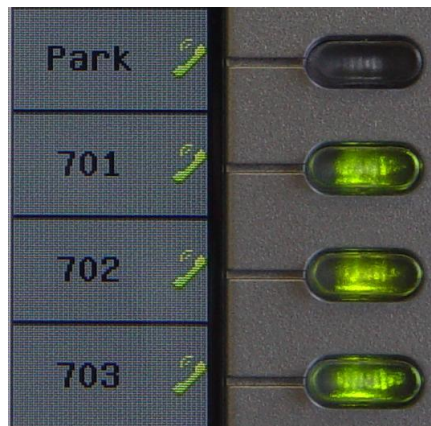











The IPitomy IP PBX is equipped with twenty (20) Park locations. Park locations are available for unique situations when a call cannot be transferred to a specific extension. Park locations are accessible by any PBX user and therefore are a general call delivery option.

Unless changed by specific application programming, the last four Programmable Buttons of your IP620 are preconfigured to operate with an elevated functionality with the first three Park locations. Button 5 is designated “Park” Call. Button 6, 7 and 8 are designated Park locations 701, 702, and 703.

Using Call Park is as simple as pressing the Park Call Button. When you do this the IPitomy IP PBX will position the call on the next available Park location (that is, if 701 is already in use, 702 will be selected.) **The IPitomy IP PBX will verbally advise you of the park location where the call has been positioned.**

You may then make a group page announcement and advise the recipient of the park location where their caller is waiting.

	Steps:	1	2	3	4
Park a Call using Park Call button	 On a call (any line)	Press  Button adjacent to Park Call	Listen for the IPitomy IP PBX to announce the Park location	 The button adjacent to the Park location will light steady red	
Park a Call using Call Transfer	 On a call (any line)	Press  OR: 	Input    Park Call code	Press  OR 	Listen for the IPitomy IP PBX to announce the Park location

Notes:



















- 1) Idle Park location buttons may be green if programmed for green on idle operation.
- 2) Users may dial the park location to retrieve a call from that call park or press a button programmed for that call park.
- 3) Calls that are retrieved from call park locations are moved from that call park location to the extension line. Hence the call park location is available for another call.
- 4) The example in the display in these instructions shows extension 4950. Your phone line number will likely be different.

28. Phonebook Individual/Enterprise







Phonebook keeps a list of contacts available for dialing. Two Phonebooks are available:

- Individual, and
- Enterprise













Phonebook entries can be assigned to groups for easy lookup. Each contact allows for three numbers.

If you want to...	Then...
Add Contacts	<ol style="list-style-type: none"> 1. Press , <ol style="list-style-type: none"> a. or press MENU button > “Phone book”, b. or press Directories button > “Phone book”; 2. Press ; 3. Select “Add contact”, press OK button or ; 4. Use the navigation keys to select content, press OK button or  to set and modify: <ol style="list-style-type: none"> a. Name: set the name of contact, b. NO.1-5: you can set up 5 contacts’ numbers, c. Group: the contacts be divided into different user’s groups 5. Press  soft key to complete
Add group	<ol style="list-style-type: none"> 1. Press  soft key, <ol style="list-style-type: none"> a. or press MENU button > “Phone book”, b. or press Directories button > “Phone book” 2. Press  soft key 3. Select the “add group” then press OK button or ; 4. Use the navigation keys to select content, press OK button or  to set and modify: <ol style="list-style-type: none"> a. Group name: name of the group b. Description: description of the group 5. Press  soft key to complete
Modify group	<ol style="list-style-type: none"> 1. Press  soft key, <ol style="list-style-type: none"> a. or press MENU button > “Phone book”, b. or press Directories button > “Phone book”; 2. Press  soft key; 3. Select the “Modify group” then press OK button or press ; 4. Select the group you want to modify, press the OK button or  to set and modify, press  to save the change
Delete group	<ol style="list-style-type: none"> 1. Press  soft key, <ol style="list-style-type: none"> a. or press MENU button > “Phone book”, b. or press Directories button > “Phone book”; 2. Press  soft key; 3. Select the “Delete group” or OK button or ; 4. Select a group you want to delete, press OK button or 

Phone Book (cont.)

If you want to...	Then...
View/Edit Contacts	<ol style="list-style-type: none"> 1. Press  soft key, <ol style="list-style-type: none"> a. or press MENU button > “Phone book”, b. or press Directories button > “Phone book”; 2. Select “View ALL”, <ol style="list-style-type: none"> a. or select a contact who are belong to different group; 3. Select the contact, press the OK button or  (to edit the contact’s information, press OK button or )
Call from phone book	<ol style="list-style-type: none"> 1. Press  soft key, <ol style="list-style-type: none"> a. or press MENU button > “Phone book”, b. or press Directories button > “Phone book”; 2. Select “View ALL”, <ol style="list-style-type: none"> a. or select a contact who are belong to different group; 3. Select a contact, then press , <p>(If there are multiple numbers of one contact, press  to enter the interface of “call options”, select the one you want to call and press )</p>







29.Speed Dial

If you want to...	Then...
Set up Speed Dial entries on your phone	<ol style="list-style-type: none"> 1. Press  or press MENU > Phonebook 2. Select Personal Phone Book 3. Select "View All". Those programmed are displayed. 4. Select a contact (or blank line for a new entry) and press  ; 5. Select the data parameter that you wish to change (Name, No. 1... etc.) 6. Press  7. Use the dial pad to input letters and numbers 8. Press  9. Press  to store this entry in the Phone Book
Cancel Speed Dials on your phone	<ol style="list-style-type: none"> 1. Press  or press Menu > Phonebook. 2. Select Personal Phone Book 3. Select "View All". Those programmed are displayed. 4. Select a contact and press  ; 5. Go to each programmed field and use  to remove data. 6. Press  7. Press  to store the changes in your Phone Book
Using Speed Dial to make calls	<ol style="list-style-type: none"> 1. Press  or press MENU > Phonebook 2. Select Personal Phone Book or Enterprise Phone Book 3. Use  and the dial pad to locate a speed dial or use the navigation keys to scroll. 4. When the entry desired is in view and selected press the corresponding button at the right or press 

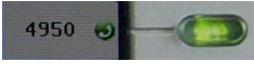
30. Transfer to Voice Mail

At times you may wish to connect a caller to a mailbox to leave a message for a user that is known to be unavailable. This is easily accomplished using the Transfer to Voice Mail function. To accomplish this operation you perform a

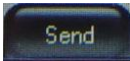
transfer as usual but preface the extension number with a . This will cause the transfer to go directly to that extension user's voice mail box greeting and allow them to leave a message.

Steps:	1	2	3	4	5
 On a call	Press  OR: 	Input 	Input  Extension No.	Press  OR 	The call is moved from your telephone to the voice mail box greeting to leave a message.

31. Voice Mail





Press the Voice Mail key on your telephone. This will bring you to a voice menu that will ask you to enter your password. Enter your password and follow the prompts to listen to messages. You should setup your voice mail for answer greetings using your voice – follow the voice-prompt directions and the guides below to help navigate all the voice mail options.

32. Voice Mail – Access from outside

When you wish to access your voice mailbox while not in the office, you can do so from the automated attendant.

- 1) Dial into the automated attendant. (Usually this is the main number or another number that has been designated for outside voice mail access.)
- 2) Dial the designated digit (assigned during installation of the IP PBX).
- 3) You will be prompted to enter your mailbox number, then your password.
- 4) Follow the prompts to listen to messages.

33. Voice Mail – Access from a phone other than your extension

- 1) From a phone inside the office, dial   .
- 2) You will be prompted to enter your mailbox number, then your password.
- 3) Follow the prompts to listen to messages.

34. Voice Mail Setup (The First Time You Log In)

The first time that you log into your mailbox you should always change some settings. In particular, you should:







- Record your name
- Record your busy greeting
- Record your unavailable greeting
- Change your password

35. Voice Mail Menus



In voice mail there are many options for handling messages and how you are able to interact with the system to retrieve and administer your messages. Once you have entered into your mailbox you have the following menu options available:

Main Menu

The main menu will be the first menu that you are presented with once you have logged in.

-  Listen to messages in the currently selected folder
-  Change folders. See Section Changing Folders for more information
-  Advanced options
-  Mailbox options (see page 25)
-  Repeat the menu options
-  Exit from the voice mail system

Advanced Options

-  Place an outgoing call
-  Leave a message for another user on the system
-  Return to the main menu

0 Mailbox Options

1 Record your unavailable message

2
ABC Record your busy message

3
DEF Record your name

4
GHI Record your temporary greeting

If there is not a temporary greeting recorded, you will immediately be prompted to record a temporary greeting. If you do have a temporary greeting recorded you will be presented with the following menu:

1 Record a temporary greeting. This will allow you to record a new temporary greeting.

2
ABC Erase temporary greeting.

Return to the main menu

Once your temporary greeting has been erased, callers will be presented with either your busy or unavailable messages, depending on your status.

0 Change your password

Return to the main menu

36.Voice Mail – Listening to Messages

The Message Envelope

The voice mail system will play back the message “Envelope”. The “Envelope” is information about the message:

- Message Number
- Date and time that the message was received
- Caller ID information
- Duration of the message

Pressing **1** while listening to the message Envelope will skip the Envelope and playback the voice message.

During Message Playback

During the playback of the message(s), any of the following buttons may be pressed:

Rewind the message by 3 seconds

#
SEND Fast forward the message by 3 seconds

0 Pause the message playback. Press any other button to resume

After Message Playback

After the message has been played back, the system will play a prompt and wait for you to press a button:

- 1** Go to the first message in the current folder
- 2** Change folders
 - 0** New messages
 - 1** Old messages
 - 2** Work messages
 - 3** Family messages
 - 4** Friends messages
 - 5** Folder 1 messages
 - 6** Folder 2 messages
 - 7** Folder 3 messages
 - 8** Folder 4 messages
 - 9** Folder 5 messages
 - #** Cancel the change folder operation
- 3** Advanced options
 - 1** Record a message and send it directly to the mailbox of the person who sent you the current message
 - 2** Call the person that left the message back
 - 3** Play the message envelope
 - 4** Place an outgoing call *May not be allowed
 - 5** Leave a message for another user on the system
 - *** Return to the main menu
- 4** Go to the previous message in the folder
- 5** Replay the current message
- 6** Go to the next message in the folder
- 7** Delete or undelete the message
- 8** Forward the message to another user on the system
- 9** Save the message to a different folder
- 0** Mailbox options
- *** Replay the prompt
- #** Exit the voice mail system

37.Voice Mailbox – Greetings

A mailbox greeting is a message for you to inform the caller that you are away from your desk or busy on another call. There are three types of Greetings:

- **Not Available Greeting – Played when your phone is un-answered:**
“Hello, this is Mark; I am not able to answer your call right now. Please leave a detailed message and a number where I can reach you, and I’ll call you back as soon as I am able.”
- **Busy Greeting – Played when your extension is busy**
“Hello, this is Mark, I am currently on the phone and not able to take your call right now; please leave a detailed message and I will call you back as soon as I can.”
- **Temporary Greeting – if there is a Temporary Greeting recorded it is the greeting that callers hear.**
The temporary greeting is played as an override for your other greetings. When the situation warrants a greeting to inform your callers of something different than your regular greetings; record a temporary greeting and it will replace the others while it is active. Be sure to go back and delete your temporary greeting to return to the normal greeting. “Hello this is Mark; I am on vacation with limited access to messages. Please call extension 1500 and speak to Mary with any matters that need immediate attention. I will return on Monday, February 24.”

Default Greetings - If you do not record any greetings, IPitomy will play a set of default greetings depending on the status of your extension. Be sure to record your name so your greeting will be a little more professional sounding. If you do not record your name, the default greeting will say “the person at extension (your extension number) is not available”. If you record your name the greeting will say “Mark Smith” is not available...”

38.Voice Mailbox – Folders

The IPitomy IP PBX allows you to save and organize your messages into folders.

There are ten folders. The first 5 folders have convenient names for organizing messages:

- New
- Old
- Work
- Family
- Friends
- Folder 1
- Folder 2
- Folder 3
- Folder 4
- Folder 5











39.Pause Key

The IPitomy Pause Key is pre-programmed on your telephone (its button number 5). Pause is similar to DND but has a broader reach. Pause will instruct the IP PBX that you are unavailable to take calls. This is different than just placing your telephone in DND because DND is local to the phone and does not provide a status for call processing operations at the PBX. When Pause is active your status is rendered as busy at any device that indicates your status. Pause also makes your extension unavailable in Groups and ACD Call Queues.

40. Phone Setup – Custom Ringing

You can select a ringing tone from a list of eight pre-programmed tones or upload a sound file to the telephone to make your telephone more distinctive among others when it is ringing.

To select your ring tone:

- 1) While busy or idle, press 
- 2) Use the Navigation keys and scroll to “System settings” and press  or .
- 3) Use the Navigation keys and scroll to “Phone settings” and press  or .
- 4) Use the Navigation keys and scroll to “Ring Type” and press  or .
- 5) All of the available ring tones will be listed here. Use the Navigation keys and select a tone/file from the list.
- 6) Press  to hear tones before selecting a tone.
- 7) Press  or  to select this tone/file.

Notes:

- 1) Uploading a sound file is not covered in this document.
- 2) Sounds files that are uploaded to your telephone will be listed with the other ring tones.

41. Phone Setup – Smart Personal Console (SPC)

Your telephone is enhanced by an integrated graphical user interface available via a web browser. This interface is called the Smart Personal Console or SPC. SPC allows:

- Change phone settings
- Program phone Programmable Buttons
- Administer Voice Mail
- Listen to Voice Mail messages
- Download Voice Mail messages
- Upload Voice Mail Box Greetings

42. SPC – Starting Smart Personal Console

- 1) Open a web browser (e.g. Firefox, Microsoft Internet Explorer)
- 2) Navigate to the IPitomy IP-PBX by entering the IP-Address of the PBX in the Address Bar. Obtain the address from your system administrator. At default the address is **192.168.1.249/ippbx**

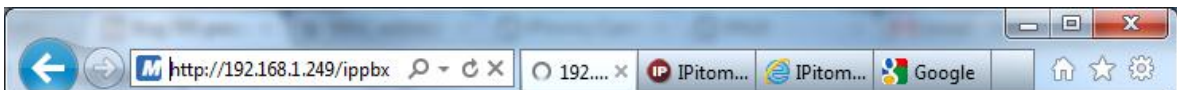

The following login screen is presented:

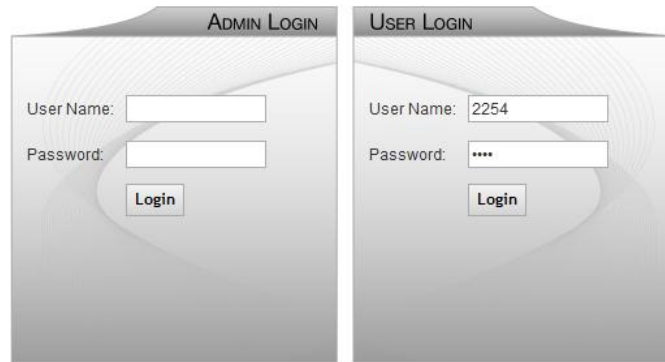

3) Input the user name and password associated to your telephone.

User Name = your telephone extension number

Password = the password used to access your voice mail (at default this is the same as your extension number)

4) Click the  button. The SPC – Home screen appears:



Leonardo da Vinci Smart Personal Console Summary

Received Calls		
From	Date	Time
2207	06/20/2011	10:36:15 AM
9413062200	06/20/2011	12:20:42 PM
9413062200	06/20/2011	12:26:46 PM
8014	06/20/2011	1:57:37 PM
8014	06/20/2011	1:57:56 PM
299	06/20/2011	2:49:38 PM
8014	06/20/2011	4:57:56 PM
2254	06/20/2011	5:26:48 PM
4045855027	06/21/2011	10:54:17 AM
299	06/21/2011	1:24:34 PM

Voicemail			
From	Date	Time	Length
2252	07/19/11	10:31:27 AM	00:21
1502	07/19/11	10:31:17 AM	00:23
2233	07/19/11	10:31:08 AM	00:21

43.SPC - Home

Here you see a short Call Log of Received calls and New Voice mail messages.

- 1) Click on the number of a Received call to open a dialog box wherein you may place a call back to that number by clicking the  button.

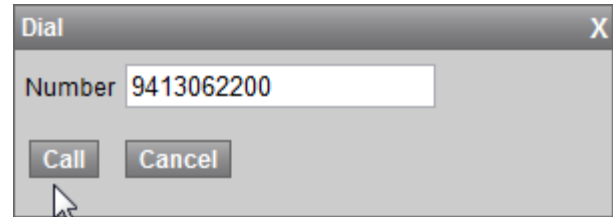

- 2) You can also Click on the  button to listen to a voice mail message, or

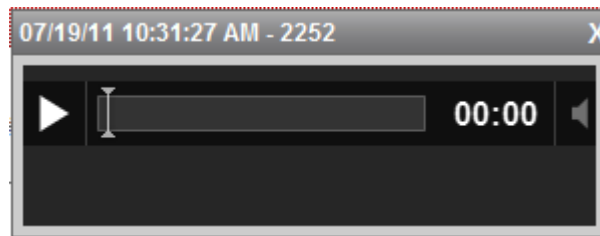

- 3) Click the  button to download the voice mail message to your PC for storage and playback whenever desired.

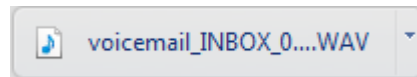

44.SPC – My Account

My Account allows you to set most features of your telephone.

[Home / My Account](#)

[Logout](#)

Leonardo da Vinci Account
Settings

[My Phone Settings](#) 

[My Schedule](#) 

Voicemail Settings	
Mailbox	<input type="text" value="2254"/> ?
Name	<input type="text" value="Leonardo da Vinci"/> ?
Password	<input type="text" value="2254"/> ?
User E-mail	<input type="text" value="daV@ipitomy.com"/> ?
Attach to E-mail	Yes <input type="radio"/> No <input checked="" type="radio"/> N/A <input type="radio"/> ?
Delete after email	Yes <input type="radio"/> No <input type="radio"/> N/A <input checked="" type="radio"/> ?
Turn Old After Emailing	Yes <input type="radio"/> No <input checked="" type="radio"/>
Say Caller Id	Yes <input checked="" type="radio"/> No <input type="radio"/> N/A <input type="radio"/> ?
Allow Review	Yes <input type="radio"/> No <input checked="" type="radio"/> N/A <input type="radio"/> ?
Allow Operator	Yes <input checked="" type="radio"/> No <input type="radio"/> N/A <input type="radio"/> ?
Play Envelope Message	Yes <input checked="" type="radio"/> No <input type="radio"/> N/A <input type="radio"/> ?
Delete Messages in	<input type="text" value="90"/> Days ?
Detect FAX:	<input type="checkbox"/>
Route Fax To:	<input type="text" value="None"/> <input type="button" value="..."/>

Follow-Me	
Manage	<input type="button" value="Numbers & Settings"/>
Forwarding	
Unconditional	<input type="text" value="Enabled"/> ?
<input type="radio"/> Phone Number	<input checked="" type="radio"/> Destination
	<input type="text" value="FollowMe"/>
	<input type="text" value="Follow-Me: 2254"/> <input type="button" value="..."/>
Busy	<input type="text" value="Disabled"/> ?
No Answer	<input type="text" value="Disabled"/> ?
Unavailable	<input type="text" value="Disabled"/> ?

My Account field descriptions

<u>Field</u>	<u>Description</u>
Mailbox	The mailbox associated to this extension. This cannot be changed in SPC
Name	The name associated to this extension. This cannot be changed in SPC
Password	Password – enter only digits to access this mailbox from a telephone
User E-mail	Email Address that is associated to this voice mail box
Attach to E-mail	Set this to yes to send a copy (.wav file) of voice messages to your email
Delete after email	Set to yes to delete voice messages that are sent to email. Caution should be taken when using this feature. Email delivery of voice mail is not monitored for success through your email provider. IPitomy sends an email and its successful delivery is subject to internet email delivery conditions.
Turn Old after Emailing	This places a voice message into the “Old Messages” folder after it has been emailed.
Say Caller ID	This plays the caller ID name/number received from the caller who left this message
Allow Review	This allows the caller to make changes to their recording prior to committing to leave the message
Allow Operator	This allows the caller to exit your voice mail box and be routed to the designated attendant.
Play Envelope Message	Envelop information is the statistical information about the message that will be played (time and date of call)
Delete Message in	This determines how long messages will be retained after being recorded
Detect FAX	Set to yes to detect a fax being sent by a caller. The performance of this feature is subject to line conditions and circuits. Some VoIP circuits do not support legacy fax functions.
Route Fax To:	This is the extension on the PBX to which a fax server is connected Use the  button to insert digits specific to the fax server that will identify this fax as a fax directed to your extension.
Follow-Me – Manage	Select the Numbers and Settings button to determine Follow-Me Forward destinations
Forward – Unconditional	PBX Forward destinations for all calls regardless of the telephone status The example shows an extension that is Unconditional Call Forwarded to a Follow-Me destination. (Follow Me 2254)
Forward – Busy	PBX Forward destinations for calls to this extension while it is busy
Forward – No Answer	PBX Forward destinations for calls to this extension that go unanswered
Forward – Unavailable	PBX Forward destinations for calls to this extension while it is determined unavailable

45.SPC – Follow-Me Forward – Numbers and Settings

Follow-Me Call Forward is a powerful feature of your IPitomy IP-PBX. Follow-Me Call Forward can be set to attempt to reach you at several locations. Locations can be searched sequentially or simultaneously using both Priority Settings and Rings to attempt at each destination. A “Type” field and “Name” field are available to organization of those destinations entered. The “Number” field is the actual number (extension or other) that will be rung for the specific entry.

Destinations (Numbers) may be programmed and disabled to allow use only while desired without having to erase and reenter specific data (“Use” check box)

Follow-Me Settings / Extension 2254

Options	
<input checked="" type="checkbox"/>	Play the Incoming message to Caller before starting search.
<input checked="" type="checkbox"/>	Record the Caller's name and play it to You.
<input checked="" type="checkbox"/>	Play the Unreachable message if You could not be found.
Add <input type="text" value="40"/>	seconds to total search time so the Callee has time to listen & respond.
Call From Prompt:	<input type="text" value="System Default"/>
No Recording Prompt:	<input type="text" value="System Default"/>
Options Prompt:	<input type="text" value="System Default"/>
Please Hold Prompt:	<input type="text" value="System Default"/>
Status Prompt:	<input type="text" value="System Default"/>
Sorry Prompt:	<input type="text" value="System Default"/>
Music On Hold	<input type="text" value="Use System Default"/>

Numbers					
Use	Priority	Rings	Type	Name	Number
<input checked="" type="checkbox"/>	<input type="text" value="1"/>	<input type="text" value="7"/>	<input type="text" value="Work"/>	Leon's desk phone	<input type="text" value="2254"/>
<input checked="" type="checkbox"/>	<input type="text" value="1"/>	<input type="text" value="7"/>	<input type="text" value="Mobile"/>	Leon's Mobile Phone	<input type="text" value="1111111111"/>
<input type="checkbox"/>	<input type="text" value="1"/>	<input type="text" value="2"/>	<input type="text" value="Mobile"/>	<input type="text"/>	<input type="text"/>
<input type="checkbox"/>	<input type="text" value="1"/>	<input type="text" value="2"/>	<input type="text" value="Mobile"/>	<input type="text"/>	<input type="text"/>
<input type="checkbox"/>	<input type="text" value="1"/>	<input type="text" value="2"/>	<input type="text" value="Mobile"/>	<input type="text"/>	<input type="text"/>
<input type="checkbox"/>	<input type="text" value="1"/>	<input type="text" value="2"/>	<input type="text" value="Mobile"/>	<input type="text"/>	<input type="text"/>
<input type="checkbox"/>	<input type="text" value="1"/>	<input type="text" value="2"/>	<input type="text" value="Mobile"/>	<input type="text"/>	<input type="text"/>
<input type="checkbox"/>	<input type="text" value="1"/>	<input type="text" value="2"/>	<input type="text" value="Mobile"/>	<input type="text"/>	<input type="text"/>
<input type="checkbox"/>	<input type="text" value="1"/>	<input type="text" value="2"/>	<input type="text" value="Mobile"/>	<input type="text"/>	<input type="text"/>
<input type="checkbox"/>	<input type="text" value="1"/>	<input type="text" value="2"/>	<input type="text" value="Mobile"/>	<input type="text"/>	<input type="text"/>

Numbers and Settings field descriptions

Fields	Description
<i>Play the Incoming Message to Caller before Starting Search</i>	When Enabled (checked), the system plays the Status Prompt to the caller.
<i>Record the Caller's Name and Play it to You</i>	When Enabled (checked), the caller will be asked to record their name, and will announce that recorded name prior to prompting the called party to accept or reject the call.
<i>Play the Unreachable Message if You Could Not Be Found</i>	When Enabled (checked), this will play the Sorry Prompt if the call is not answered, otherwise it goes right to the voicemail greeting.
<i>Number of Seconds to Total Search Time so Caller Has Time to Listen & Record</i>	This allows you to configure how many seconds the system will spend searching for the called party. Default is 12 seconds.
<i>Call From Prompt</i>	This plays when Record the Caller's Name and Play it to You is enabled (checked). The system default message is "Incoming Call From" followed by the recording the caller made of their name.
<i>No Recording Prompt</i>	This plays when Record the Caller's Name and Play it to You is disabled (not checked). The system default message of "You have an incoming call" followed by the Options Prompt.
<i>Options Prompt</i>	This plays after you have answered the call and prompts you to press either "1" to accept the call or "2" to reject the call. The system default message can be changed, but the options remain the same.
<i>Please Hold Prompt</i>	This plays to the caller alerting them that the system is going to find the user they are trying to reach. The system default message of "Please hold while I try to locate the person you are calling" will play during the search process.
<i>Status Prompt</i>	This plays the system default message of "The person you are calling is not at their desk, I will try to locate them for you" .
<i>Sorry Prompt</i>	This plays if the person could not be reached or they reject the call. The system default message of "I'm sorry, but I was unable to locate the person you were calling" .
<i>Music On Hold</i>	This allows you to specify a particular Music On Hold playlist to play to the caller during the search process. The system default Music on Hold (set at PBX Setup→Music on Hold) will play when this parameter is set to system default.
<i>Numbers</i>	If selected (checked), the Follow Me feature will try to either simultaneously or in sequence of priority to try and locate you by using this call list.

46.SPC – My Account – My Phone Settings:

Toward the top of the My Accounts page is the [My Phone Settings](#)  link. This link directs you to many other options that can be set on your telephone. The heading of each category are:

Key Settings
Audio Settings
SIP / Network Settings
Display Settings
Expansion Modules



It is important to note that making changes to your telephone via SPC is the preferred technique since it is the only technique that is retained by the PBX for upgrades and backup operations.

Note: click the [Back to Smart Personal Console](#) link to return to SPC.

47.SPC – My Phone Settings – Key Settings

#	Key Type	Label	Value
0	Reserved		
1	Reserved		
2	Reserved		
3	Reserved		
4	Park	Park	
5	BLF	701	701:Park_701
6	BLF	702	702:Park_702
7	BLF	703	703:Park_703

Audio Settings
SIP / Network Settings
Display Settings
Expansion Modules

Copyright ©2011 IPitomy Communications, LLC
www.ipitomy.com | (941) 306-2200 | support@ipitomy.com

The Programmable Buttons of the IP620 are available here for assignment. In the picture, the first four buttons (0-3) are “Reserved”. This means that they have been assigned in database administration as Line buttons and are not available for program options through SPC.

For those buttons that can be programmed here, click on the drop-down list of possible button functions.

Key Settings – Button Functions

When programming buttons, you select from the available options and then program the contents if required – for instance, when programming a BLF (Busy Lamp Field) you must program the extension that is covered with this BLF. Use the table as a guide to what data is required.

Button Function	Data Required
BLF	Extension Number
Speed Dial	Number to dial
Park	700, 701-720
Call Pickup	99
Voicemail	923
Voicemail Gateway	924
Record	*#

Button Function	Data Required
Fwd On	*91
Fwd Off	*90
Set Fwd	*92
Fwd Gateway	*9
Pause	ABC<ext#>
Day/Night	ff
Page/BLF	**<ext#>

Note: click the [Back to Smart Personal Console](#) link to return to SPC.

48.SPC – My Phone Settings – Audio Settings

Audio Settings allow you to tailor the characteristics of your telephone’s sound connections. Use these settings to obtain the best possible connection for each of the devices; Handset, Headset, and Speakerphone.

Note: click the [Back to Smart Personal Console](#) link to return to SPC.

49.SPC – My Phone Settings – SIP / Network Settings

Key Settings
Audio Settings
SIP / Network Settings
SIP Settings
SIP Location <input type="text" value="LAN"/> <input type="text" value="192.168.2.18"/>
DTMF Mode <input type="text" value="Follow Server"/>
Time Settings
Time Server Location <input type="text" value="Use PBX as Time Server"/> <input type="text" value="192.168.2.18"/>
Configuration Updates
Protocol <input type="text" value="HTTP"/>
Web Port <input type="text" value="80"/>
Display Settings
Expansion Modules
<input type="button" value="Save"/> <input type="button" value="Save and Configure"/>
Copyright ©2011 IPitomy Communications, LLC www.ipitomy.com (941) 306-2200 support@ipitomy.com

These higher-level settings determine network connectivity and telephone specific operational settings. It's best not to change these unless you are very familiar with how your changes will affect the operation of your telephone. It is possible to set your telephone for use with the associated PBX while in a different location by setting the "SIP Location" to WAN. In this case the system administrator must have already set the Public IP Address of the Router where the PBX is located.

This valuable feature will allow you to use your telephone almost anywhere you wish. It is critical however that all high-level programming be in place prior to making these adjustments.

Consult your network administrator prior to making any changes on this page.

Note: click the [Back to Smart Personal Console](#) link to return to SPC.

50.SPC – My Phone Settings – Display Settings

Settings in this area affect the operation of the display for both:

- Color graphic display
- BLF lamp operation

The screenshot shows a web interface for configuring a phone. It has a sidebar menu with the following items: Key Settings, Audio Settings, SIP / Network Settings, and Display Settings (which is currently selected). The main content area is titled "Display Settings" and contains the following controls:

- BLF Green for Idle: A dropdown menu set to "Enabled".
- Backlight Mode: A dropdown menu set to "On".
- Backlight Timer: A numeric input field set to "60" with up and down arrow buttons.
- Contrast Level: A numeric input field set to "3" with up and down arrow buttons.
- Backlight Level: A numeric input field set to "3" with up and down arrow buttons.

At the bottom of the settings area, there are two buttons: "Save" and "Save and Configure". Below the buttons is a footer section containing the following text:

Expansion Modules
Copyright ©2011 IPitomy Communications, LLC
www.ipitomy.com | (941) 306-2200 | support@ipitomy.com

Often legacy telephone systems use BLF (Busy Lamp Field) indicators for extensions on the system. This is of course possible on your IP PBX as well however the function of green LED status is available for use as an idle status indicator for a BLF of another extension. To use this, select "Enabled" on "Green for Idle" for the BLF button programmed on your phone. This will indicate to you that an extension is programmed on that button. It will light steady red when the extension is busy or unavailable and flash red when that extension is ringing.

Use the other settings to adjust your display for your desired contrast and brightness.

The Backlight can be set for On (always ON), Off (always OFF), or Timed which will keep it bright after use for the length of the time set in Backlight Timer.

Note: click the [Back to Smart Personal Console](#) link to return to SPC.

51.SPC – My Phone Settings – Expansion Modules

Key Settings

Audio Settings

SIP / Network Settings

Display Settings

Expansion Modules

Number of Modules

#	Key Type	Label	Value
8	<input type="text" value="BLF"/>	<input type="text" value="Tonie Office"/>	<input type="text" value="299:Tonie Office"/>
9	<input type="text" value="BLF"/>	<input type="text" value="Elaine"/>	<input type="text" value="2208:Elaine Blodgett"/>
10	<input type="text" value="BLF"/>	<input type="text" value="Jill"/>	<input type="text" value="2206:Jill Salazar"/>
11	<input type="text" value="BLF"/>	<input type="text" value="EJ"/>	<input type="text" value="2207:EJ Donovan"/>
12	<input type="text" value="BLF"/>	<input type="text" value="David"/>	<input type="text" value="2210:David Lindsey"/>
13	<input type="text" value="BLF"/>	<input type="text" value="Darren"/>	<input type="text" value="2212:Darren Kretz"/>
14	<input type="text" value="BLF"/>	<input type="text" value="Darren iPad"/>	<input type="text" value="1810:Darren IPAD"/>
15	<input type="text" value="BLF"/>	<input type="text" value="Darren SP"/>	<input type="text" value="1809:Darren Softphone"/>

Copyright ©2011 IPitomy Communications, LLC

www.ipitomy.com | (941) 306-2200 | support@ipitomy.com

When your IP620 is equipped with one or more (up to six maximum) IPX32 Expansion Modules, you have an additional 32 buttons per module that can be programmed for various functions. Select the Expansion Modules programming tab to enter into the programming of buttons on the units installed onto your telephone. You must select the Module number first (“1” for the first, “2” for the second...) then program buttons as you would under Key Settings.

Note: click the [Back to Smart Personal Console](#) link to return to SPC.

52.SPC – My Schedule

Toward the top of the My Accounts page is the [My Schedule](#)  link. This link directs you to a schedule table which allows you to set call routing of calls to your extension based on the time of day and day of week.

My Schedule / Extension 2254 / Call Routing

Edit Schedule							
Name:	<input type="text" value="ext_2254"/>						
	M	T	W	Th	F	Sat	Sun
Hours of Operation:	Start: <input type="text" value="8:30 am"/>	<input type="text" value="8:30 am"/>	<input type="text" value="8:30 am"/>	<input type="text" value="8:30 am"/>	<input type="text" value="8:30 am"/>	<input type="text" value="none"/>	<input type="text" value="none"/>
	Stop: <input type="text" value="5:30 am"/>	<input type="text" value="5:30 am"/>	<input type="text" value="5:30 am"/>	<input type="text" value="5:30 am"/>	<input type="text" value="5:30 am"/>	<input type="text" value="12:15 am"/>	<input type="text" value="12:15 am"/>
In Hours Destination:	<input type="text" value="Extensions"/>		<input type="text" value="Extension: 2254"/>		<input type="text" value="..."/>	<input checked="" type="checkbox"/> Apply Forward Settings?	
Outside of Hours Destination:	<input type="text" value="None"/>		<input type="text" value=""/>	<input type="text" value="..."/>	<input type="checkbox"/> Apply Forward Settings?		
	M	T	W	Th	F	Sat	Sun
Lunch hours:	Start: <input type="text" value="12:30 pm"/>	<input type="text" value="12:30 pm"/>	<input type="text" value="12:30 pm"/>	<input type="text" value="12:30 pm"/>	<input type="text" value="12:30 pm"/>	<input type="text" value="none"/>	<input type="text" value="none"/>
	Stop: <input type="text" value="1:30 pm"/>	<input type="text" value="1:30 pm"/>	<input type="text" value="1:30 pm"/>	<input type="text" value="1:30 pm"/>	<input type="text" value="1:30 pm"/>	<input type="text" value="12:15 am"/>	<input type="text" value="12:15 am"/>
Lunch Hours Destination:	<input type="text" value="Voicemail"/>		<input type="text" value="Voicemail: 2254"/>		<input type="text" value="..."/>	<input type="checkbox"/> Apply Forward Settings?	

Save Changes

In the example above the Name is set to “ext_2254” – this is the name of this schedule. It can be changed but will not be displayed in any other location that affects phone usage.

Time is broken into three categories (modes of operation):

- Hours of Operation
- Outside of Hours
- Lunch Hours

Use the various entries to set destinations and time periods for each mode. Use the  icon to input additional call handling digits whenever required.

Notice that “Apply Forward Settings” is checked yes for Hours of Operation and not Outside of Hours. This will have the effect of following the Follow-Me forward programming that is set on the extension only during office hours.

Notice too that at lunch hours we are directing calls to this extension to the extension’s voice mailbox directly. No need to ring the phone during this time.

Call Forwarding

























53.SPC – Call Log

Home / Call Log

Logout

Leonardo da Vinci Call Log

First < 1 2 3 4 5 6 7 8 9 10 11 > Last

Call History					
Date/Time	Direction	Source	Destination	Duration	Status
Jul 18 05:34 pm	Internal	 2252	2254	0:00:04	CANCEL
Jul 18 05:10 pm	Internal	2254	 2252	0:00:11	ANSWER
Jul 18 04:13 pm	Internal	2254	 2252	0:00:15	ANSWER
Jul 15 04:55 pm	Internal	 8014	2254	0:00:07	ANSWER
Jul 15 04:54 pm	Internal	 8014	2254	0:00:07	ANSWER
Jul 15 04:49 pm	Internal	2254	 2252	0:00:55	ANSWER
Jul 15 04:33 pm	Internal	2254	 4950	0:00:09	CANCEL
Jul 15 04:26 pm	Internal	2254	 4950	0:00:09	CANCEL
Jul 15 04:25 pm	Internal	2254	 4950	0:00:07	CANCEL
Jul 15 04:24 pm	Internal	2254	 2252	0:00:08	CANCEL
Jul 15 04:21 pm	Internal	2254	 4950	0:00:39	ANSWER
Jul 15 03:54 pm	Internal	2254	 4952	0:00:01	CHANUNAVAIL
Jul 15 03:53 pm	Internal	2254	 4951	0:00:01	CHANUNAVAIL
Jul 15 10:18 am	Internal	 2207	2254	0:00:01	CHANUNAVAIL
Jul 14 03:17 pm	Internal	 2252	 2253	0:00:02	CHANUNAVAIL
Jul 14 02:18 pm	Internal	 2252	 2255	0:00:02	CHANUNAVAIL
Jul 14 01:30 pm	Internal	 2207	 2253	0:00:02	CHANUNAVAIL
Jul 14 12:26 pm	Internal	 1502	 2253	0:00:02	CHANUNAVAIL
Jul 14 12:21 pm	Internal	 1502	 2253	0:00:02	CHANUNAVAIL
Jul 14 11:03 am	Internal	 8014	2254	0:00:05	ANSWER

In SPC Call Log it is possible to review all of the calls in the log that have been received and placed. From the log information about the call can be found... internal/external, direction of the call etc.

It is also possible to place calls from this list.

When a call is displayed and you'd like to place a call to that number, click on the icon  next to the number and a

Dial dialog box will open allowing you to make that call.

When making a call in this way:

- 1) Click Dial
- 2) Your telephone will ring
- 3) Answer your telephone
- 4) You will hear ringing after you answer – as the call to the call log number is now in progress.

54.SPC – Voice Mail

Home / Voicemail Logout

Leonardo da Vinci Voicemail Details

All Current Folder  [My Greetings](#)

Show Custom Folders

 [New \(2\)](#) 

 [Family](#)







 [Friends](#)

 [Work](#)



 [Old](#)

You are using the Default System Greeting.

New 2 Messages | Previous 1-2 Next

Voicemail						
<input type="checkbox"/>	From	Call Back #	Date	Time	Length	
<input type="checkbox"/>	Paul 410	 2252	07/19/11	10:31:27 AM	00:21	 
<input type="checkbox"/>	Paul Office Test	 1502	07/19/11	10:31:17 AM	00:23	 

When you select Voice Mail in SPC, you enter into the New Messages *folder*. There are five categorized *folders* and five custom *folders* available as part of standard voice mail. The New folder is where all voice messages are kept automatically. Once they are heard they can be stored in any of the available folders for organized replay later.

Use the checkboxes to select message and move them to folders as you wish. You can also play  messages and download  messages to your PC. Callback is also possible from Voice Mail... ..

55.SPC – Voice Mail – My Greetings

Voice Mailbox Greeting can be programmed from either a telephone or by uploading a file that is prerecorded. Recording your greetings via you telephone is the most common technique and is covered in the section Voice Mail Setup and Voice Mail Menus – Mailbox Options . However it is possible to make your greeting extraordinary by prerecording the greeting and splicing it with music. This adds a very dynamic quality to your greeting.

If you have the ability to make such a recording great, if not, consider having one done professionally.



When it is prepared, upload  it to the system for the greeting appropriate (Name, Busy, Unavailable, or Temporary). You must be familiar with standard file upload operations to succeed in this endeavor. If not seek the help of a helpful geek.

All
 Current Folder

 [My Greetings](#)

Show Custom Folders







 [New](#)

 [Family \(2\)](#) 

 [Friends](#)

 [Work](#)

You are using the Default System Greeting.

Voicemail			
<input type="checkbox"/> Name	Status	Length	
<input type="checkbox"/> Name	Enabled	00:03	  
<input type="checkbox"/> Busy	System Default	00:00	
<input type="checkbox"/> Unavailable	System Default	00:00	
<input type="checkbox"/> Temporary	System Default	00:00	

56.SPC Exit



You can exit from SPC at any time using the Logout button at the upper-right of the web page.

57.Volume Adjustments – Receivers/Speaker

Your IP620 telephone has the ability to adjust volume settings in both directions for the call types:















- Handset
- Speakerphone
- Headset

This will allow you to fine-tune your telephone for the best possible audio connection in each of the various modes.

	Status	Adjust Listening Volume
Handset	Handset off-hook	 <p>Press the Volume Bar Up/Down to adjust the volume level for the mode in operation</p>
Speakerphone	 Speaker Button	
Headset	 Headset Button	
Ring	Telephone Idle	

58.No

Volume Adjustment – Microphones

- 1) While busy or idle, press 
 - 2) Use the Navigation keys and scroll to “System settings” and press  or .
 - 3) Use the Navigation keys and scroll to “Phone settings” and press  or .
 - 4) Use the Navigation keys and scroll to “Volume settings” and press  or .
 - 5) Use the Navigation keys and scroll to the desired device to adjust and press  or .
 - Ring volume (same as that adjusted using Volume Bar while phone is idle.)
 - Handset volume (Same as that adjusted using Volume Bar while using Handset.)
 - **Handset mic volume** – use to adjust the microphone level of the handset
 - Speaker volume (Same as that adjusted using Volume Bar while using Speakerphone.)
 - **Speaker mic volume** – use to adjust the microphone level of the Speakerphone
 - Headset volume (Same as that adjusted using Volume Bar while using Headset.)
 - **Headset mic volume** – use to adjust the microphone level of the headset
- 6) Press  or .
 - 7) Use the Navigation keys and scroll to the desired Volume Level and press  or .
 - 8) The new setting is saved for this device. Press  to exit the menu.

59. Menu





















Your IP620 has many settings available via its MENU function. They are listed below.

Language	English only is available at this time
English	
Functions	Features and resources on the phone
Auto Answer	Enable/Disable
DND	Do Not Disturb – Phone based
Account01 – 06 Enable/Disable	Enable/Disable per account
Message code	Used to assign the code that is associated to the VM button
Hot Line	Number to dial when this phone goes off-hook
Hot Line	Enable/Disable + Number (immediate)
Warn Line	Enable/Disable + Number (Hot Line after 3s pause)
Time & Date	Time and Date settings – usually serviced by PBX
SNTP	
SIP Server	
Manual Setting	
VOIP Call Forward	Telephone Call Forwarding (Independent of PBX CFWD)
All Calls	
Unconditional Transfer	Enable/Disable
Number	
If Busy	
Busy Transfer	Enable/Disable
Number	
If No Answer	
No Answer Transfer	Enable/Disable
Number	
Program Key	
Programmable Keys 1 – 8	
Mode	
Speed Dial	Programmed with a number to dial when pressed
Asterisk BLF	BLF = Busy Lamp Field Shows the status of the monitored extension and can be used to call/transfer that extension. May also be used to pick up calls that are ringing at that extension.
Speed Dial Prefix	Programmed with a number to insert prior to subsequent actions
BLA	not used at this time
DTMF	Used to send DTMF tones per telephony interface needs
Account SIP Account 1 - 2	Allows assignment of the button action to one or any of the installed SIP Accounts.
Name	Label for this button (reference and printout purposes)
Number	The actual value (content) of the button
Calls	History of calls
Missed Calls	
Received Calls	
Dialed numbers	
Contacts	Phone Book
Enterprise phone book	Future Release
Personal phone book	Future Release
Messages	Future Release
Create Message	Future Release
Inbox	Future Release

Settings	System Settings
Phone Settings	
Volume Settings	
Ring Volume	Levels 0 – 9 possible
Handset Volume	Levels 0 – 9 possible
Handset Microphone Volume	Levels 0 – 7 possible
Speaker Volume	Levels 0 – 9 possible
Speaker Microphone Volume	Levels 0 – 7 possible
Headset Volume	Levels 0 – 9 possible
Headset Microphone Volume	Levels 0 – 7 possible
Ring Type	Bellcore-DR1 – 8, you may select from files that are uploaded
Brightness	Level 1 – 5
Contrast	Level 1 – 5
Baklite off time	Time that backlight stays on after activity (“0” means always ON)
Advanced Settings	Password Protected – at default password is <blank>
Network	Various settings for network connection
VLAN	LAN/PC Port VLAN settings
SIP	Global/Accounts/Auto Provision
Load Default Settings	Are you sure you want to do that?
Reboot	Restart the phone
Modify Password	
TR069	Boot-up configuration method – not yet supported
Status	View the current settings
Network	
Lines	
Software	
Diagnose	
Keys	Enter into mode and press one key a t a time to check response
LCD	Lights LCD at full brightness
Lights	Press “OK” to cycle through all LED modes
Sound	Press “OK” for echo-repeat test

60. Buttons and Codes

Personal Voicemail:		Dial this to access your personal voicemail box from your extension.
Voicemail Main:		Dial this to reach the voice mail system from any extension or the automated attendant.
Transfer to Voicemail:	 + ext #	Use this to transfer a caller directly to someone's mailbox when you don't want to ring their extension
Directory:		IPitomy's directory and dial by name service
Blind Transfer:		Use this to transfer a caller when you don't need to speak to the party you are transferring to before sending them the call
Attended Transfer:		Use this when you want to ask the party if they would like to speak to the caller first before transferring
One Touch Record:		This will record the conversation (Requires Permission)
Pickup Extension:		Dial this to pick up a ringing extension from your phone
Directed Pickup Extension:	 + ext #	Dial this to pick up a specific extension.
Ring Group Page:	 + ext #	Dial this to page someone over their speaker phone
Pause Phone Queues:		Pause phone in all Queues (ACD Feature)
Un-pause Phone Queues:		Return phone to Queue (ACD Feature)
Pause Agent Queues:	 + Agent #	Pause agent in all queues (ACD Feature)
Un-pause Agent Queues:	 + Agent #	Return Agent to Queue (ACD Feature)
Agent Callback Login:		Following the in-call instructions allows for the agent to login at any phone. Once logged in, to log out you will follow the instructions, and when asked
Agent Login:		This logs the agent in at the phone the code was dialed at. In order to remain logged in, the phone must stay off-hook. To log out, simply hang up.
PBX Call Forward		PBX-based Call Forward. Enable/Disable access and voice prompted menu to input number where calls will be forwarded.
PBX Call Forward Destination		PBX-based Call Forward. Direct access to forward destination entry.
PBX Call Forward Cancel (disable)		PBX-based Call Forward. Direct access to disable function.